

	Date	Name	
Author	23.03.2018	laubeg	
Check			
Norm			
DistributionUnit			1
			A3

6 5 4 3 2 1

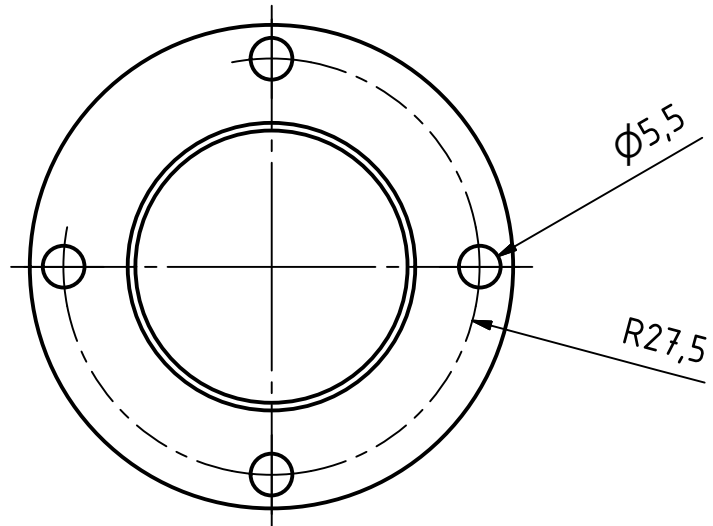

	Date	Name	
Author	10.04.2017	laubeg	
Check			
Norm			
		Material: PVC	
		SpringHousing	
		1	
		A3	

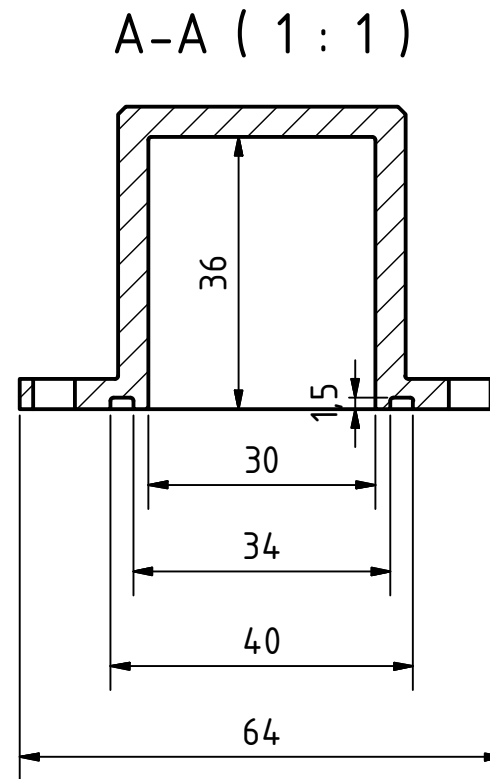
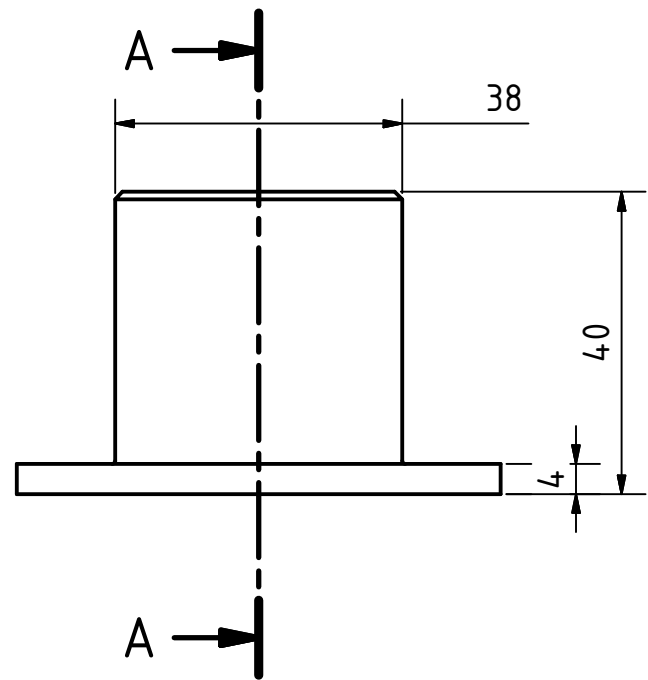
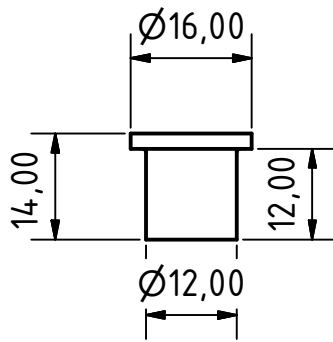
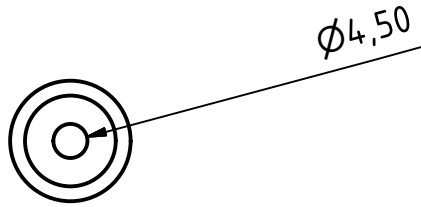

	Date	Name		Material: Stainless Steel	
Author	10.04.2017	laubeg			
Check					
Norm					
				SpringGuide	
				1	
				A4	

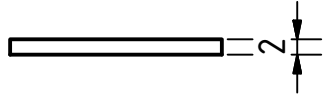
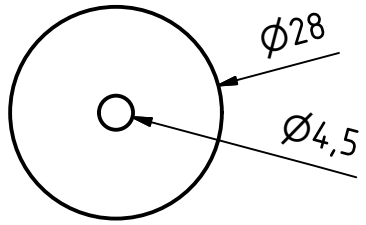

	Date	Name		Material: Stainless Steel	
Author	10.04.2017	laubeg			
Check					
Norm					
		SpringWasher			1
					A4

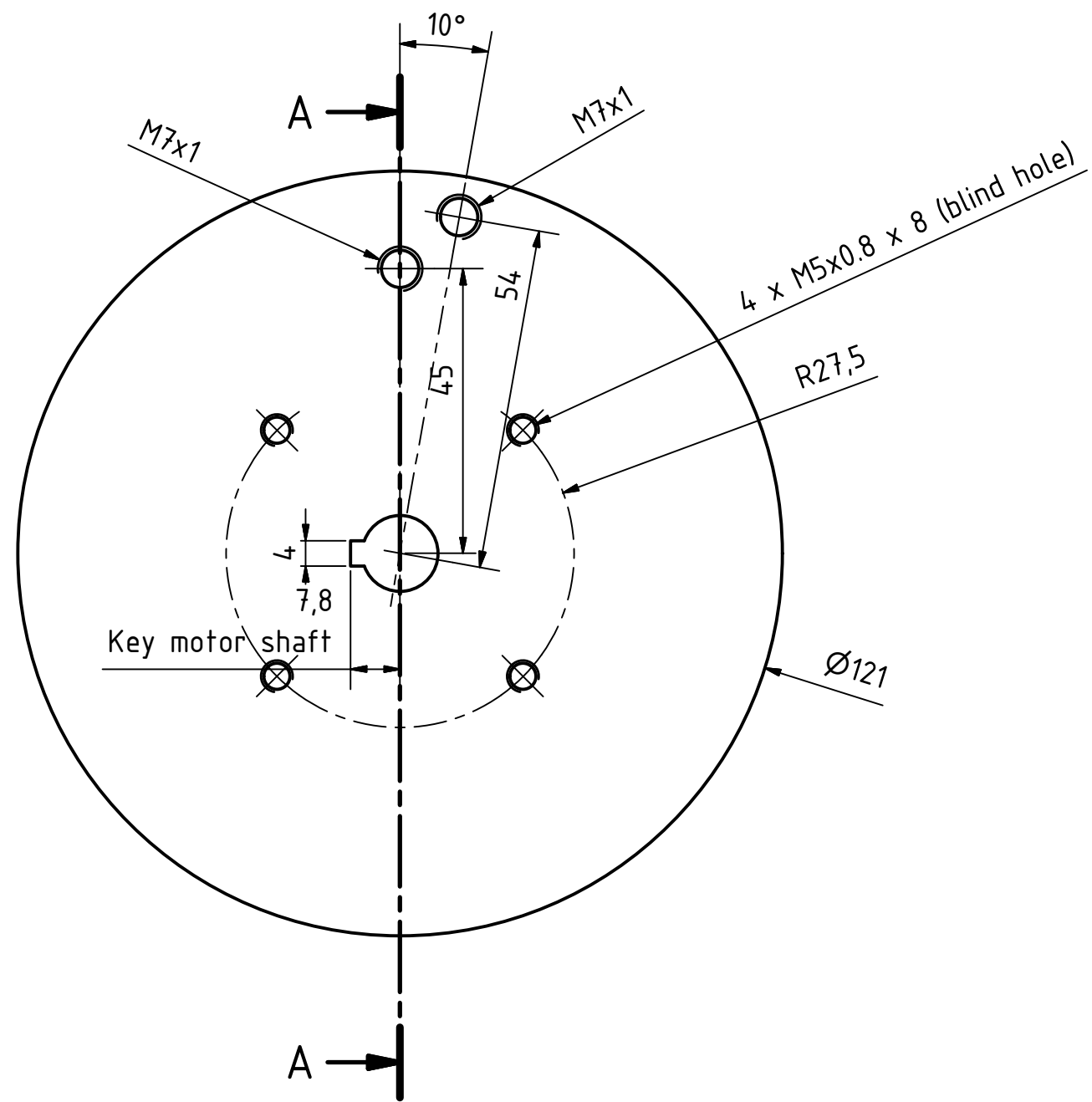

A-A (1 : 1)

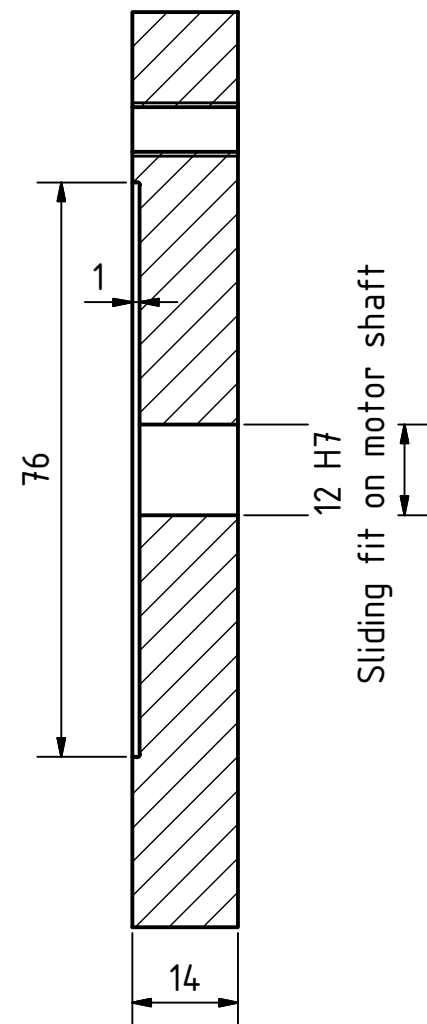

	Date	Name	
Author	10.04.2017	laubeg	
Check			
Norm			
		Material: PTFE	
		Rotor	
		1	
		A3	

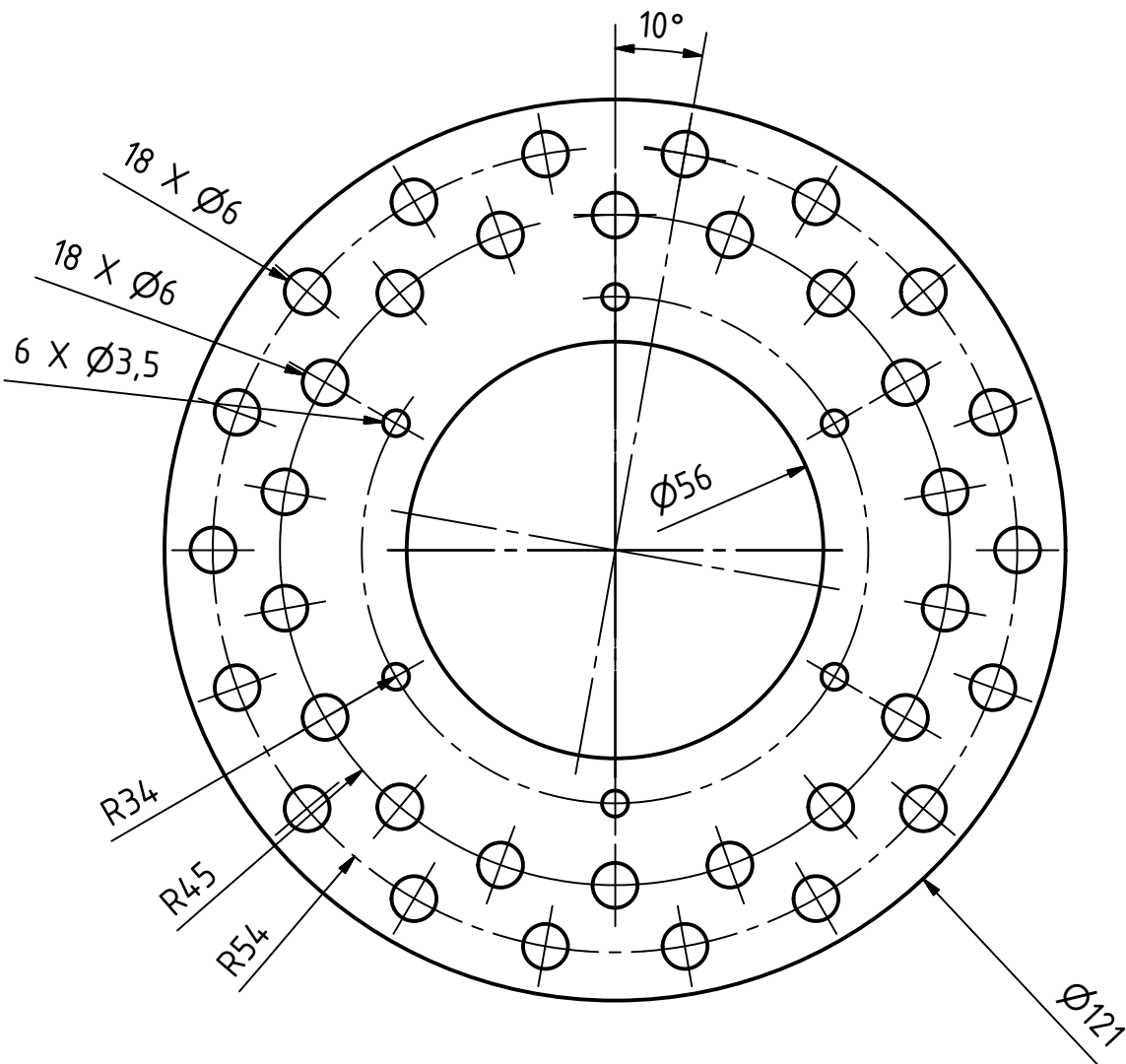

	Date	Name		Material: Neopren (CR) Foam	
Author	25.04.2017	laubeg			
Check					
Norm					
				SealingWithoutCountersink ¹	
				A4	

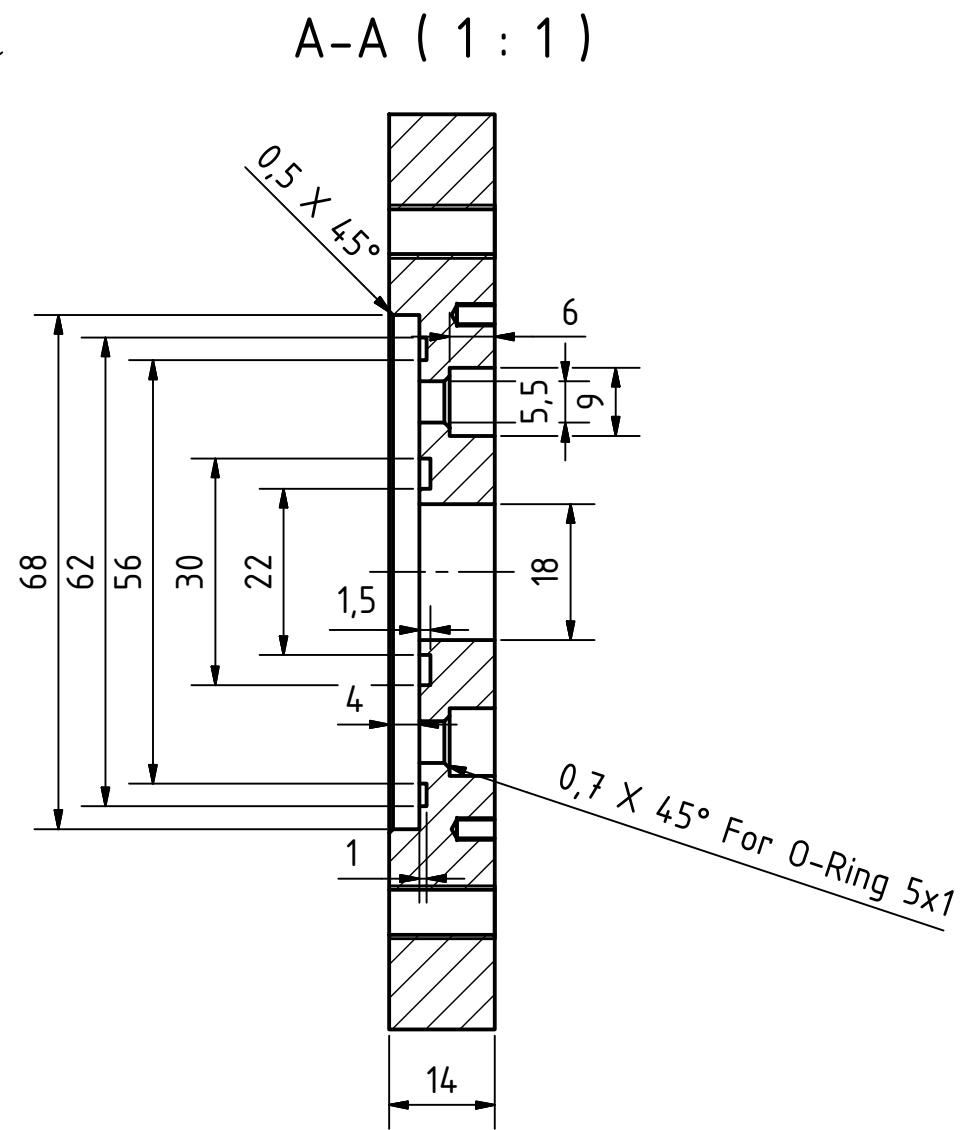
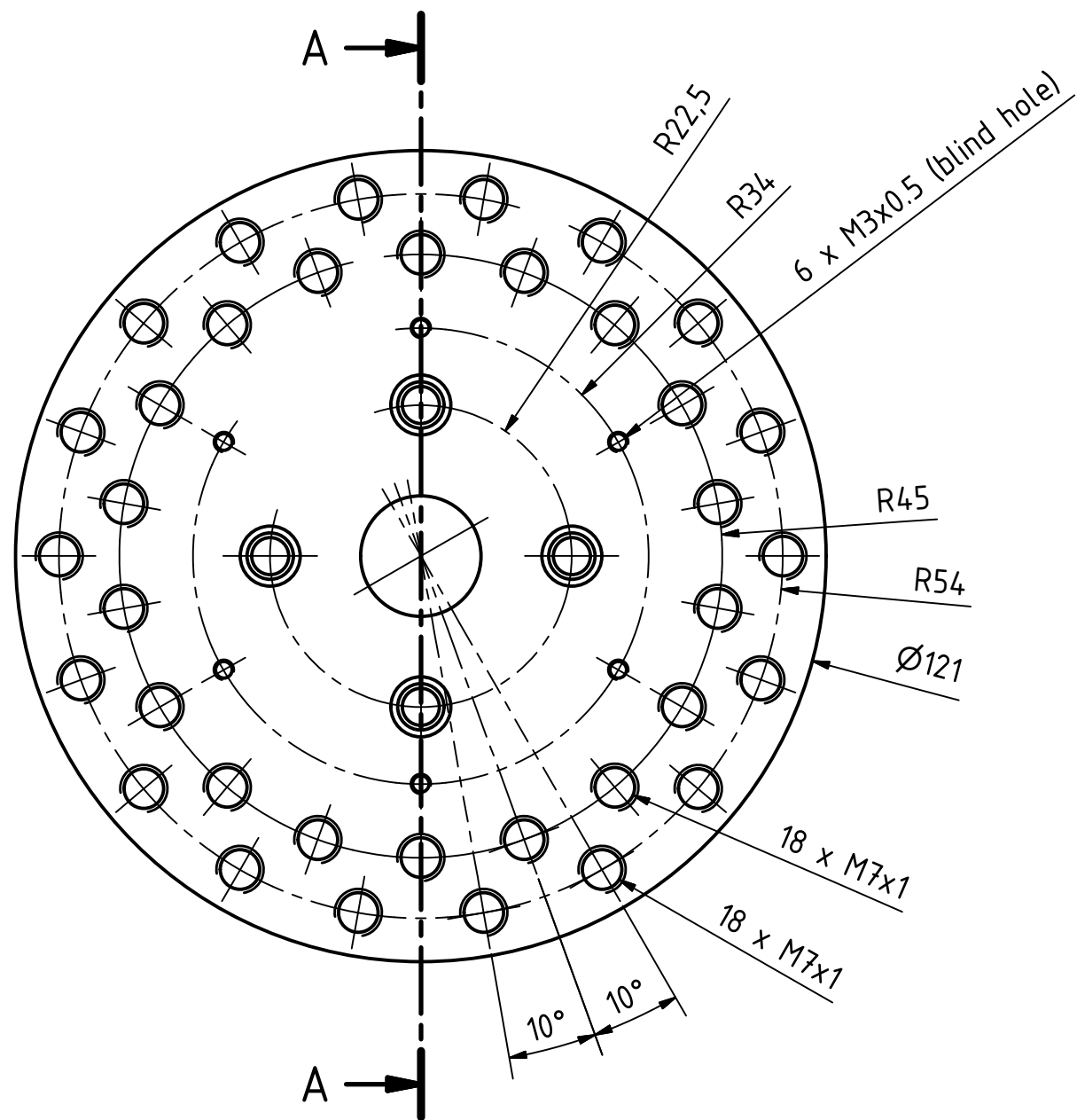

	Date	Name	Material: PVC
Author	10.04.2017	laubeg	
Check			
Norm			
Stator			1
			A3

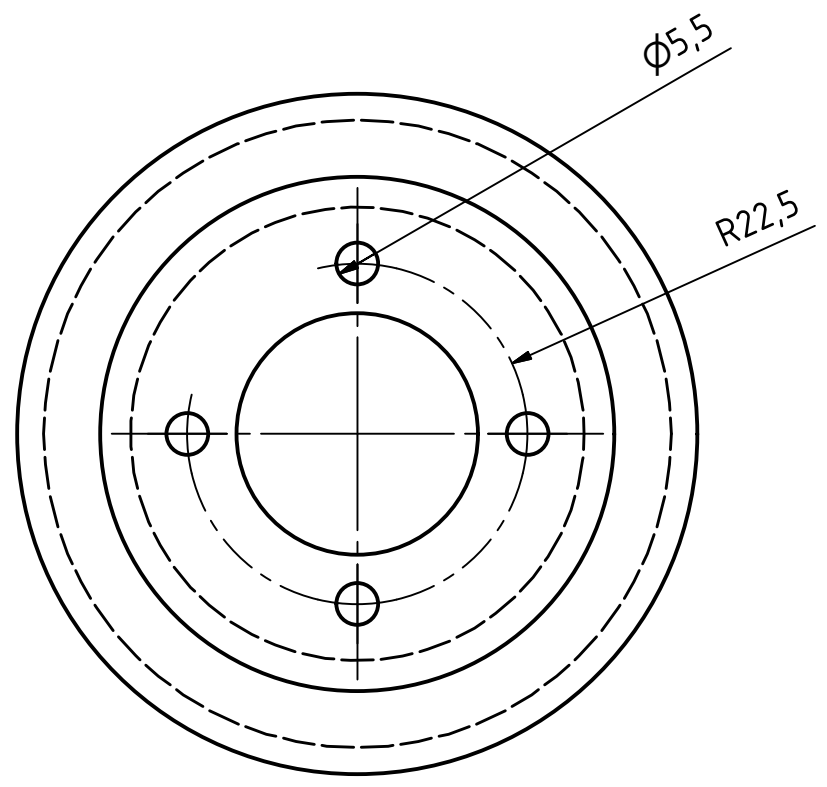
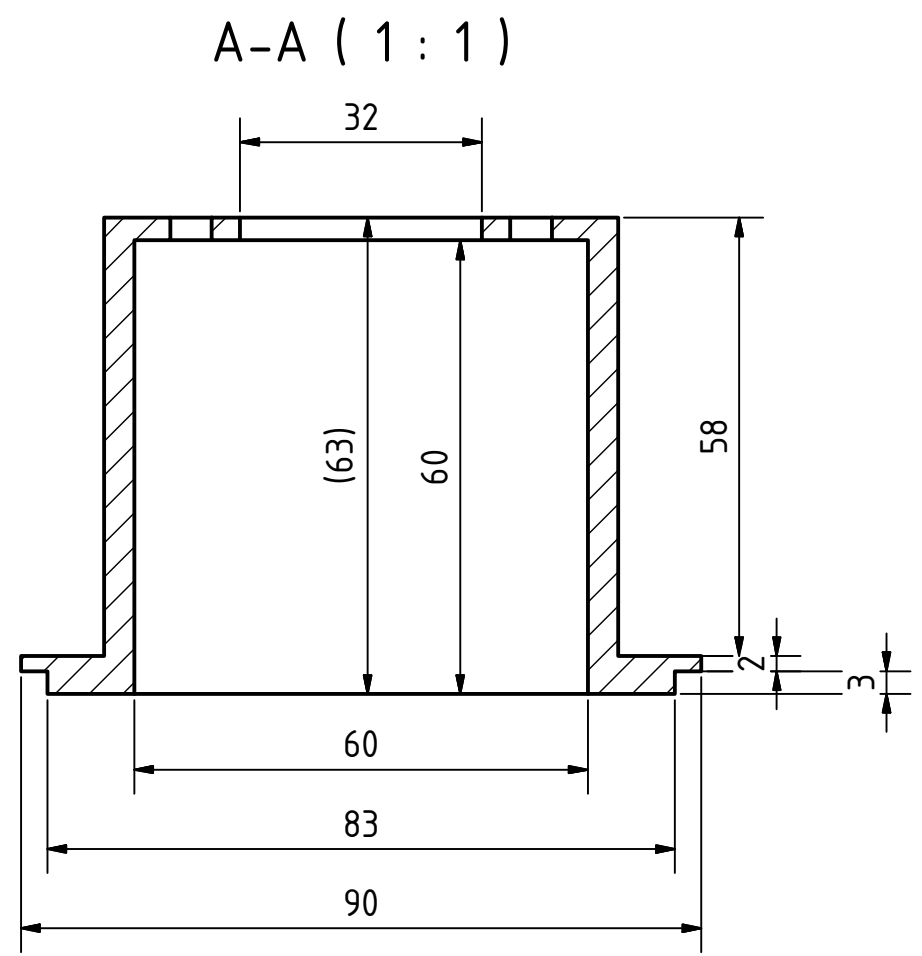
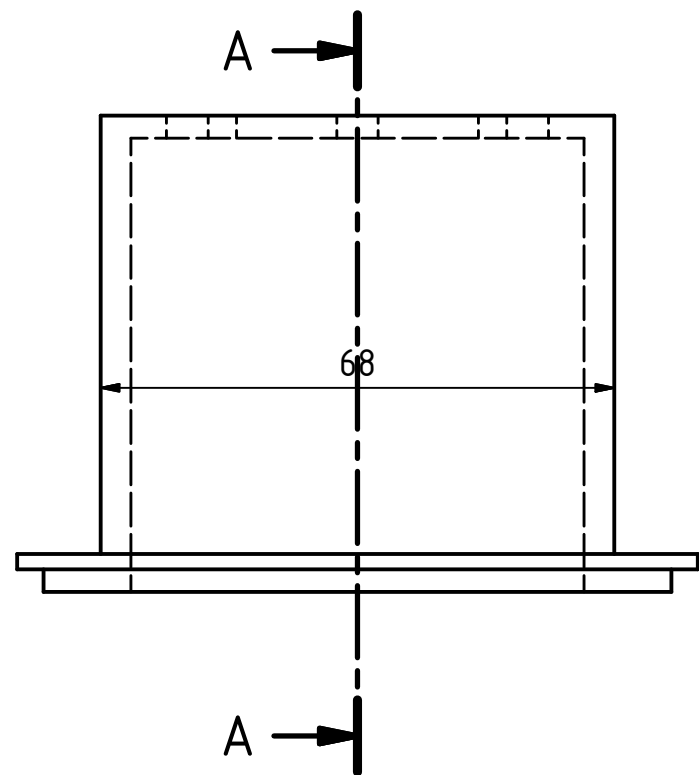

	Date	Name		Material: Stainless Steel	
Author	10.04.2017	laubeg			
Check					
Norm					
				MotorHousingUpper	
				1	
				A3	

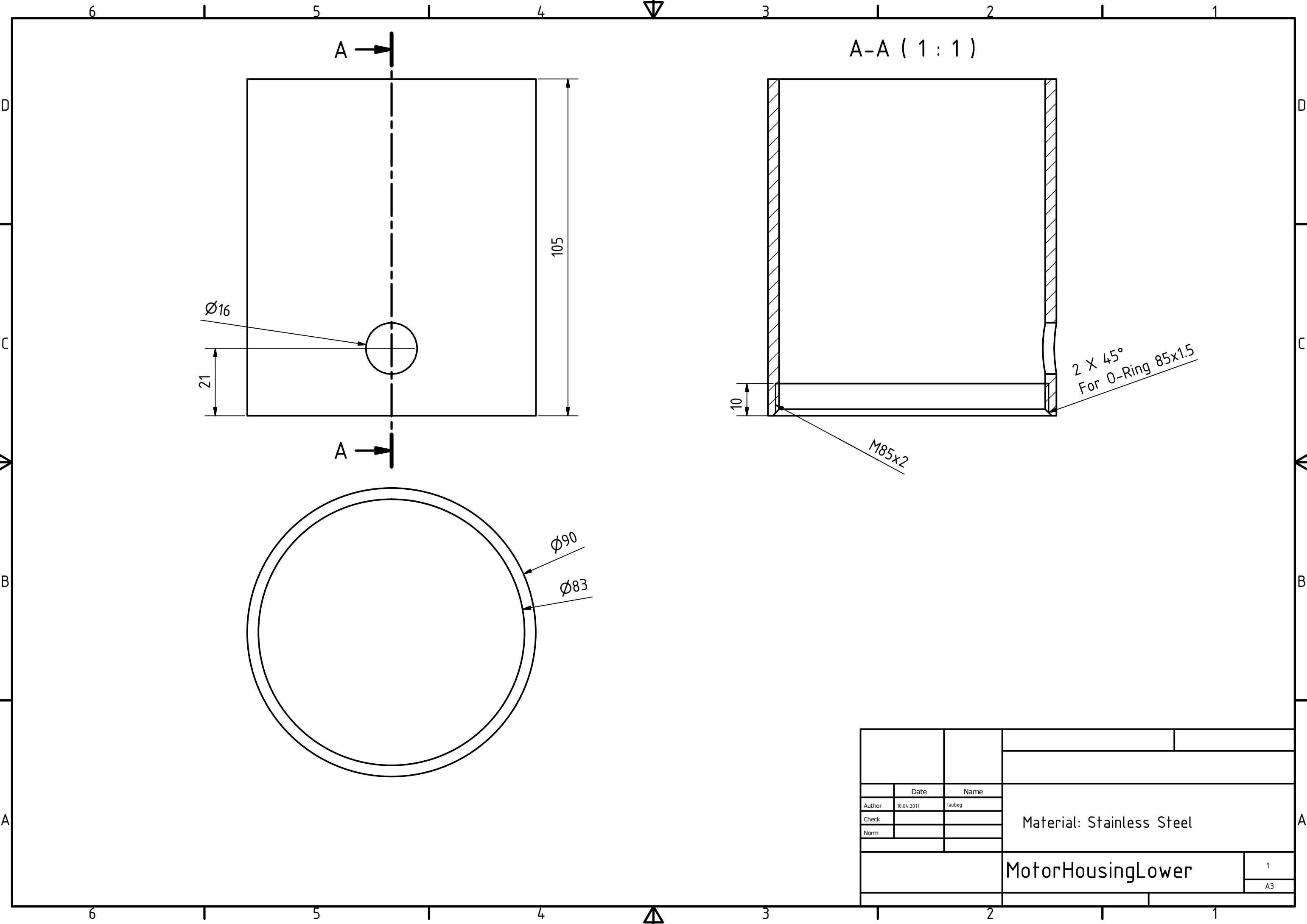

	Date	Name		Material: Stainless Steel	
Author	10.04.2017	laubeg			
Check					
Norm					
				MotorHousingLower	
				1	
				A3	

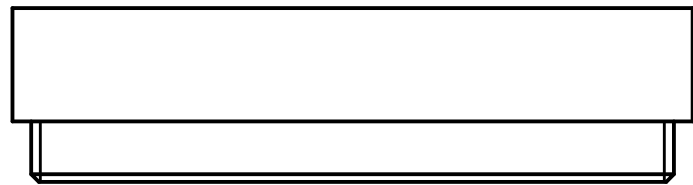
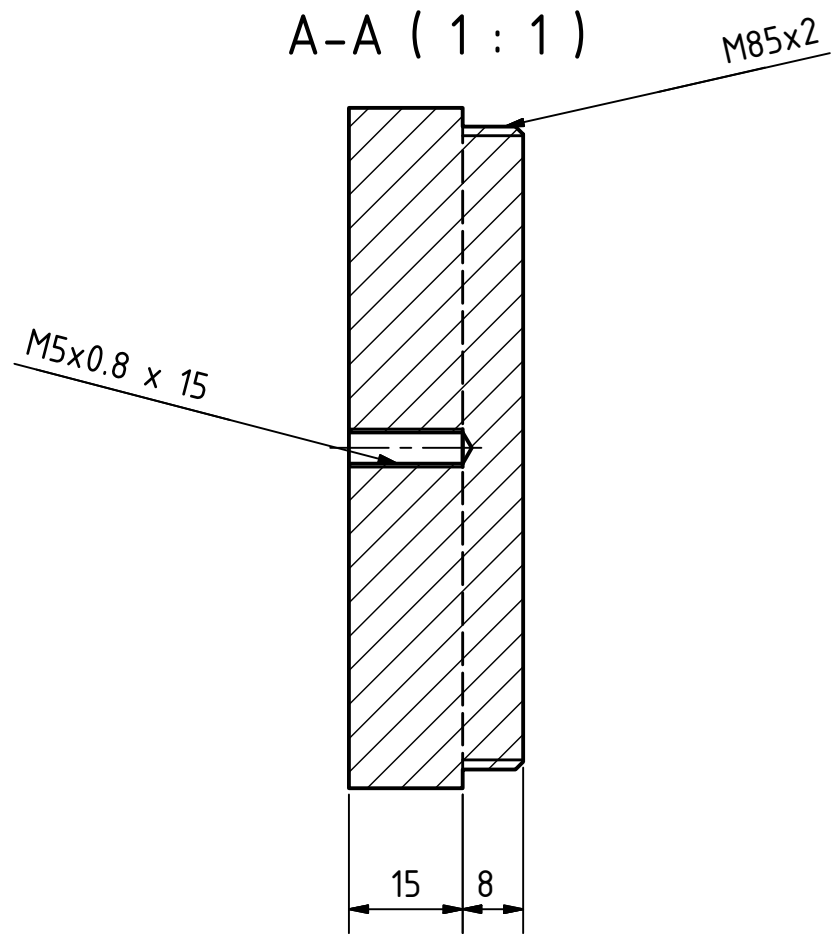
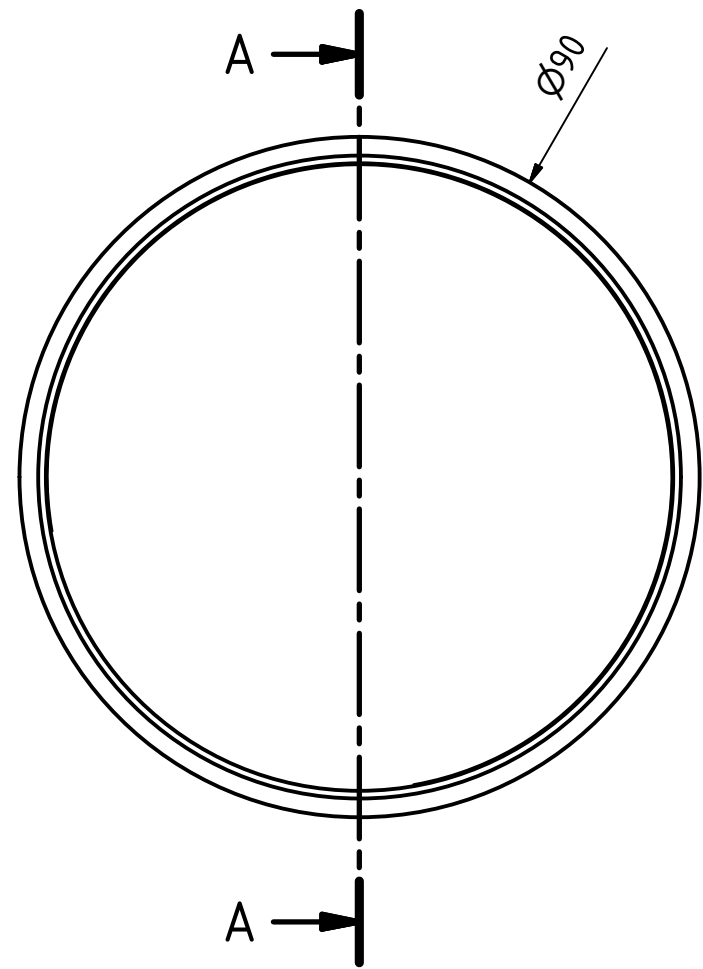

	Date	Name	
Author	10.04.2017	laubeg	
Check			
Norm			
		Material: PVC	
		MotorHousingLid	
		1	
		A3	